

ACELERADOR DE EXTRAÇÃO - PAE

Material: DIN 1.7225

Dureza: 55 ± 3 HRC

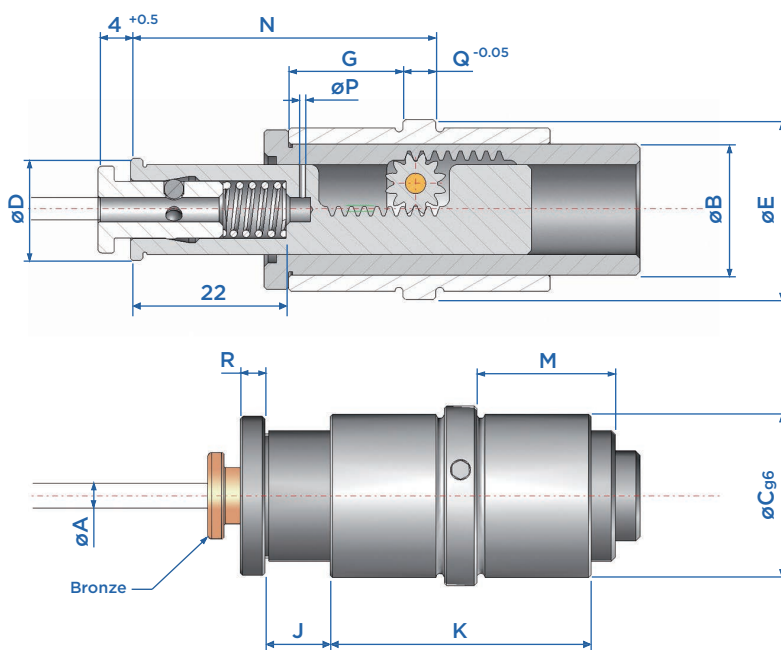
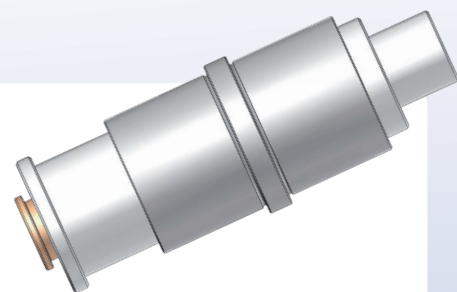

Código	A	B	C	D	E	F	G	J	K	L	M	N	P	Q	R
PAE031620	3	16	20	12.5	22	13	14	8	32	22	17	37	/	4	3
PAE041620	4	16	20	12.5	22	13	14	8	32	22	17	37	/	4	3
PAE052430	5	24	30	16	34	16	20	15	44	36	27	57	2	4	3
PAE062430	6	24	30	16	34	16	20	15	44	36	27	57	2	4	3
PAE082430	8	24	30	17	34	17	20	15	44	36	27	57	2	4	3
PAE103036	10	30	36	21.5	40	21	28	20	62	46	34	78	2	6	4
PAE123036	12	30	36	21.5	40	21	28	20	62	46	34	78	2	6	4

Aplicação e Funcionamento

